

**CHAIN BLOCK – RIGTECH ELITE MODEL**



**APPLICATIONS**

- Suitable for applications in the mining, construction, industrial and automotive industries

**CONSTRUCTION**

- Allowable ambient conditions
  - » Operating temperature range: -10°C to +60°C
  - » Operating humidity: 100% relative humidity or less; this product should not be used under water

**PRODUCT FEATURES**

- Relevant standards: AS/NZS 1418.2 and EN 13157
- Key internal components are CNC machined and adhere to the most stringent machine tolerances
- 'T' type hooks for improved load holding
- Gear system design for easy lifting

Product Code	Rated Capacity (kg)	Lifting Height (m)	Minimum Distance Between Hooks - Hmin (mm)	Hand Force Fully Loaded (N)	No. of Load Chain Falls	Load Chain G80 (mm)	Hand Chain (mm)	Dimensions (mm)				Net Weight (kg)	Extra Weight per Meter (kg)
								A	B	C	D		
RTCB0.53	500	3	280	208	1	5x15	5x23.7	130	128	23.6	30	5.98	0.94
RTCB13	1000	3	330	283	1	6.3x19	5x23.7	150	142	28	35.5	9.56	0.94
RTCB23	2000	3	385	355	1	8x24	5x23.7	185	175	33.5	42.5	16.20	0.94
RTCB33	3000	3	510	340	2	7.1x21	5x23.7	220	158	37	36	20.20	0.94

**TECHNICAL DRAWINGS**

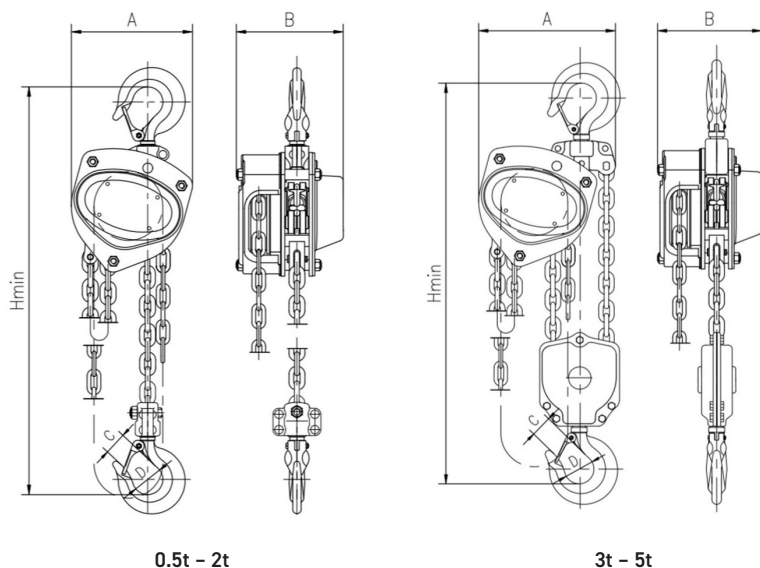

**SPARE PARTS**

Product Code	Bottom Hook	Top Hook	Safety Latch
RTCB0.53	RTCBBH0.5	RTCBTH0.5	RTCBSL0.5
RTCB13	RTCBBH1	RTCBTH1	RTCBSL1
RTCB23	RTCBBH2	RTCBTH2	RTCBSL2
RTCB33	RTCBBH3	RTCBTH3	RTCBSL3

Chain & Rigging has taken every precaution to ensure accurate information on this data page, but accept no liability for any errors or omissions. Chain & Rigging reserves the right to modify specifications at any time.